

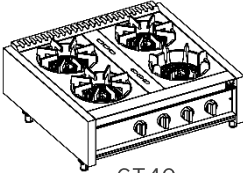

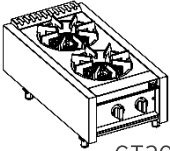



KITCHEN WORKS is registered trademark of Kitchen Works Co. Ltd.

Project: _____
 Item: _____
 Quantity: _____

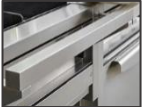
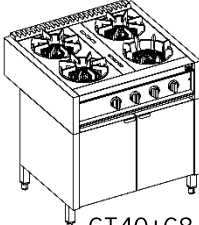
Burner Range Series

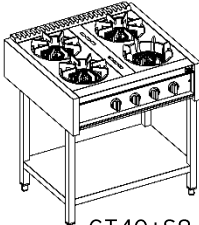
Model	<input type="checkbox"/> GR40-GB	<input type="checkbox"/> GT40	<input type="checkbox"/> GT20
 GR40-GB	<p>Standard Features:</p> <ul style="list-style-type: none"> • Construction in AISI 304 stainless steel on front, side and adjustable feet • Signature 10kW 2-stage cast iron gas burners • Flame failure protection for all burners • Electric spark ignition on all pilots • Heavy duty cast iron grates • Stainless steel drip tray positioned under open burners • Unit comes with stainless steel front working rail • Suitable for Towngas, LPG and natural gas <p>Oven Features:</p> <ul style="list-style-type: none"> • Ordinary oven with heavy duty stainless steel door hinge • 8kW stainless steel U-burner provides even heating throughout the oven • Mirror stainless steel oven interior and 5mm thick steel base • Unit comes with chrome plated oven racks and can accommodate standard pans • Oven with temperature control range from 110°C to 290°C <p>NOTE: Please specify gas type when ordering.</p>		
 GT40	 GT20		

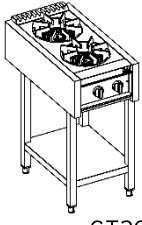
Stainless Steel Accessories (only for model GT40 & GT20)			
	<input type="checkbox"/> F1: stainless steel front working rail 124 x 200 mm (H) <input type="checkbox"/> 400 <input type="checkbox"/> 600 <input type="checkbox"/> 800 <input type="checkbox"/> 1200 <input type="checkbox"/> Custom made _____ mm (W)	 GT40+C8	
	<input type="checkbox"/> C8: stainless steel base cabinet 800 x 580 x 620 mm (H)		
	<input type="checkbox"/> S8: stainless steel stand w/ bottom shelf 800 x 530 x 620 mm (H)	 GT40+S8	
	<input type="checkbox"/> S4: stainless steel stand w/ bottom shelf 400 x 530 x 620 mm (H)	 GT20+S4	

KWS/BRS/SS/202006



KITCHEN WORKS is registered trademark of Kitchen Works Co. Ltd.

Burner Range Series

Specifications	GR40-GB	GT40	GT20
Type	Free standing	Countertop	Countertop
Cast Iron Grate	3 x flat top + 1 x wok	3 x flat top + 1 x wok	2 x flat top
Burner Rate (kW/BTU)	4 x 10 (4 x 35,000)	4 x 10 (4 x 35,000)	2 x 10 (2 x 35,000)
Oven Rate (kW/BTU)	1 x 8 (1 x 28,000)	-	-
Oven Temperature	110°C ~ 290°C	-	-
Oven Interior Dimensions (mm)	580 W 660 D 310 H	-	-
Gas Inlet Size	Ø25mm (1") N.P.T.	Ø25mm (1") N.P.T.	Ø20mm (3/4") N.P.T.
Net Weight (kg)	148	66	36
Dimensions (mm)	800 W 750 D 850 H	800 W 750 D 280 H	400 W 750 D 280 H

KWS/BRS/SS/202006