

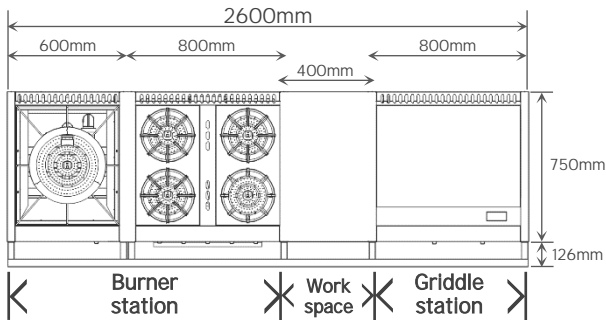

KITCHEN WORKS is registered trademark of Kitchen Works Co. Ltd.

Burner + Grill & Griddle Stations (BGLGS) – Recommendation 2



List of item(s)

- GR101 Bulk cooking range
- SP1 S/S grease stopper
- GR40-GB 4-burner range w/ oven
- SP3 S/S spreader unit w/ GN slides
- GTG27 Countertop griddle range
- S8 S/S stand w/ bottom shelf

Optional Item(s)

- SF-2600W S/S front work rail

32KW SUPER POWERFUL BURNER FOR BULK COOKING

10KW @ 2-RING BURNER COMES W/ FLAT TOP AND WOK GRATES THAT ARE INTERCHANGABLE



SPREADER TOP AND FRONT WORK RAIL ARE USED TO EXTEND WORK SURFACE TO SUPPORT COOKING ON BOTH SIDES

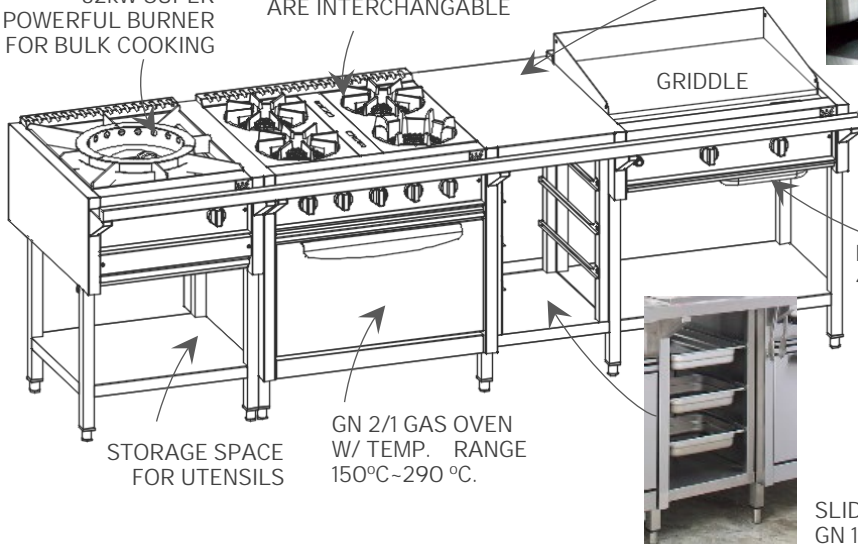

KWS'S NOTES

- This setting of burner and griddle station is suitable for a high output kitchen that serves Asian and Western cuisine.
- Electric spark ignition to burner is more energy saving comparing with constant burning pilot light.
- Front, side and adjustable legs of all ranges are made of AISI 304 stainless steel which make it extremely robust and durable.
- Bulk cooking range is used for big wok frying, braising, boiling, steaming etc.
- Front work rail is highly recommended to be added as optional item, if space is allowed. It can hold GN 1/9 garnish pans, cooking tweezer, towel etc, and use as an extended work surface to support cooking.
- Backsplash can be added as optional item. It allows 120 mm piping space between the wall and the back of cooking range for running E&M services, if necessary.

KWS/BGLGSR2/20200

Copyright © 2020 Kitchen Works Co. Ltd.