

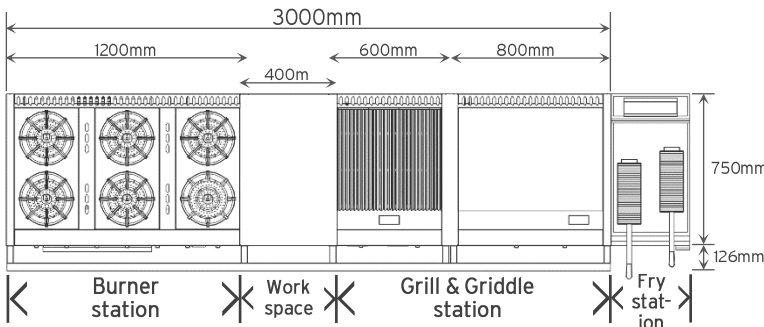

KITCHEN WORKS is registered trademark of Kitchen Works Co. Ltd.

Burner + Grill & Griddle Stations (BGLGS) - Recommendation 3



List of item(s)

- GR60-GCB 6-burner range w/ convection oven
- SP3 S/S spreader unit w/ GN slides
- GTGL26 Countertop grill ranged
- SP1 S/S grease stopper
- GTG27 Countertop griddle range

Optional Item(s)

- SF-3000W S/S front work rail
- Low refrigerator
- Fryer station

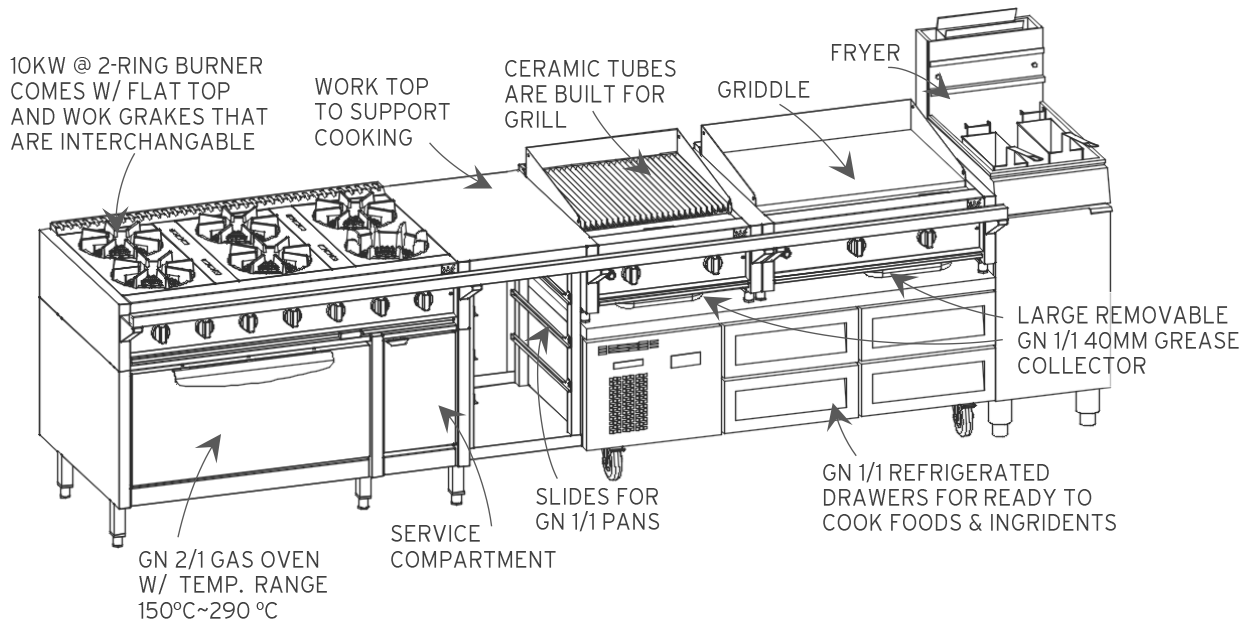

KWS'S NOTES

- This is a comprehensive setting of burner and griddle stations for a high output kitchen that serves Asian and Western cuisine or a production kitchen.
- Electric spark ignition to burner is more energy saving comparing with constant burning pilot light.
- Front, side and adjustable legs of all ranges are made of AISI 304 stainless steel which make it extremely robust and durable.
- Bulk cooking range can be added as optional item for big wok frying, braising, boiling, steaming etc.
- Low refrigerator can be added as optional item for efficiency of cooking.
- Fryer station can be added next to griddle, if necessary.
- Front rail is highly recommended to be added as optional item, if space is allowed.
- Backsplash can be added as optional item to allow piping space for running E&M services, if necessary.

KWS/BGLGR2/202005

Copyright © 2020 Kitchen Works Co. Ltd.